

- NOTES:
1. OVERALL HEIGHT IS IN LOADED CONDITION. UNLOADED HEIGHTS MAY BE 4" ABOVE HEIGHTS SHOWN.
  2. DO NOT SCALE DRAWING.
  3. ALL DIMENSIONS ARE APPROXIMATE AND SUBJECT TO ENGINEERING CHANGES.
  4. DRAWING MAY OR MAY NOT SHOW ALL ITEMS AS DESCRIBED IN THE WRITTEN DETAIL SPECIFICATIONS.
  5. INCLUSION OF AN ITEM ON THE DRAWING DOES NOT CONSTITUTE INCLUSION OF THAT ITEM WITH THE FINAL DELIVERED UNIT.
  6. THE EFFECTIVE DOOR OPENINGS WILL BE APPROX. 2" LESS THAN THE NOTED COMPARTMENT OPENING FOR ROLL UP DOORS AND UP TO APPROX. 4" LESS FOR HINGED DOORS

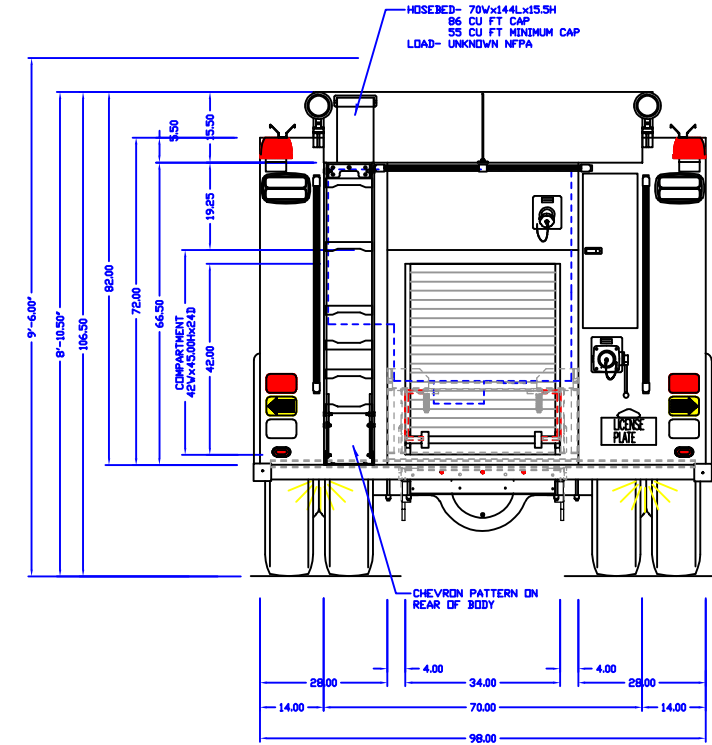
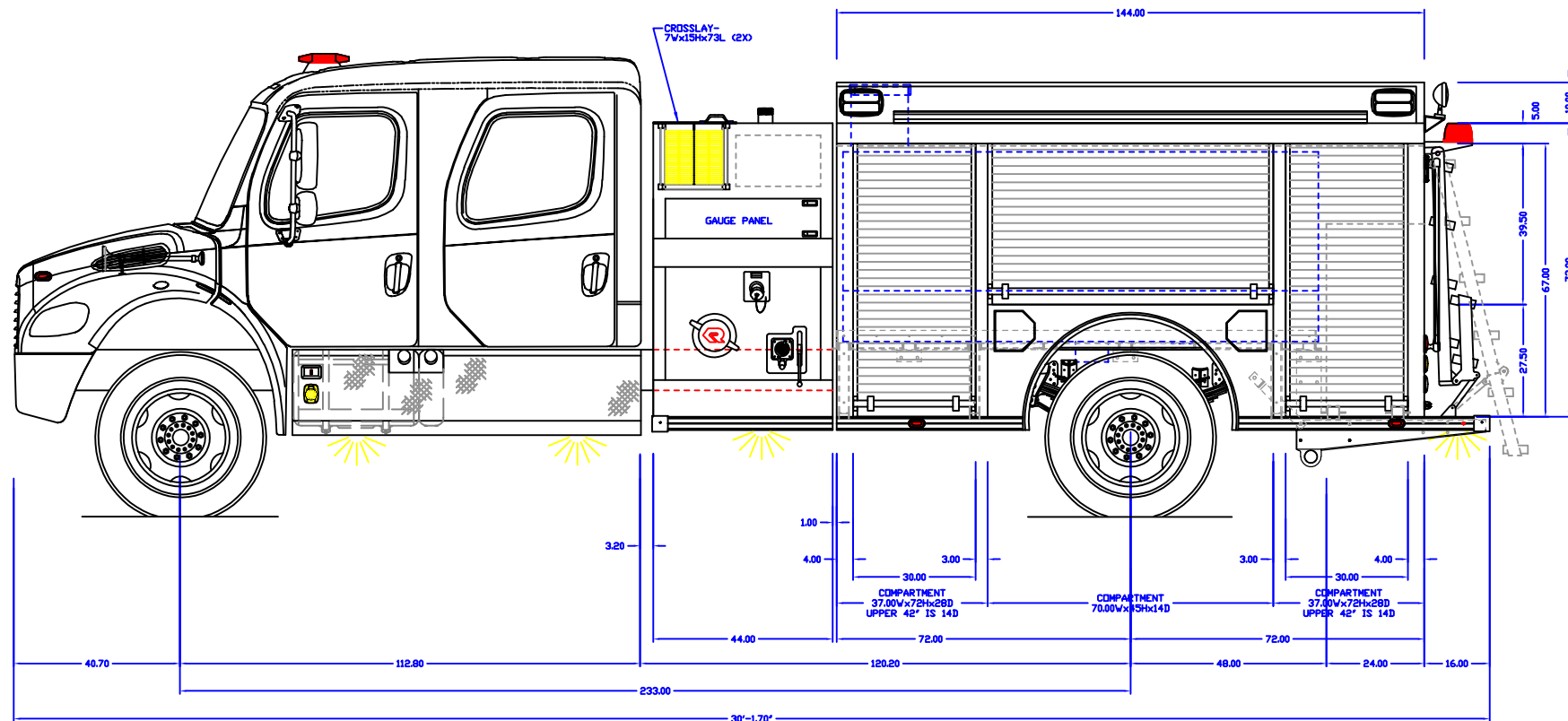

INITIALS: HF  
 JOB NUMBER: 18003  
 DATE: 7/29/2019

MAIN FILE: -  
 DEPT: -  
 DEALER: -

PRODUCTION APPROVED

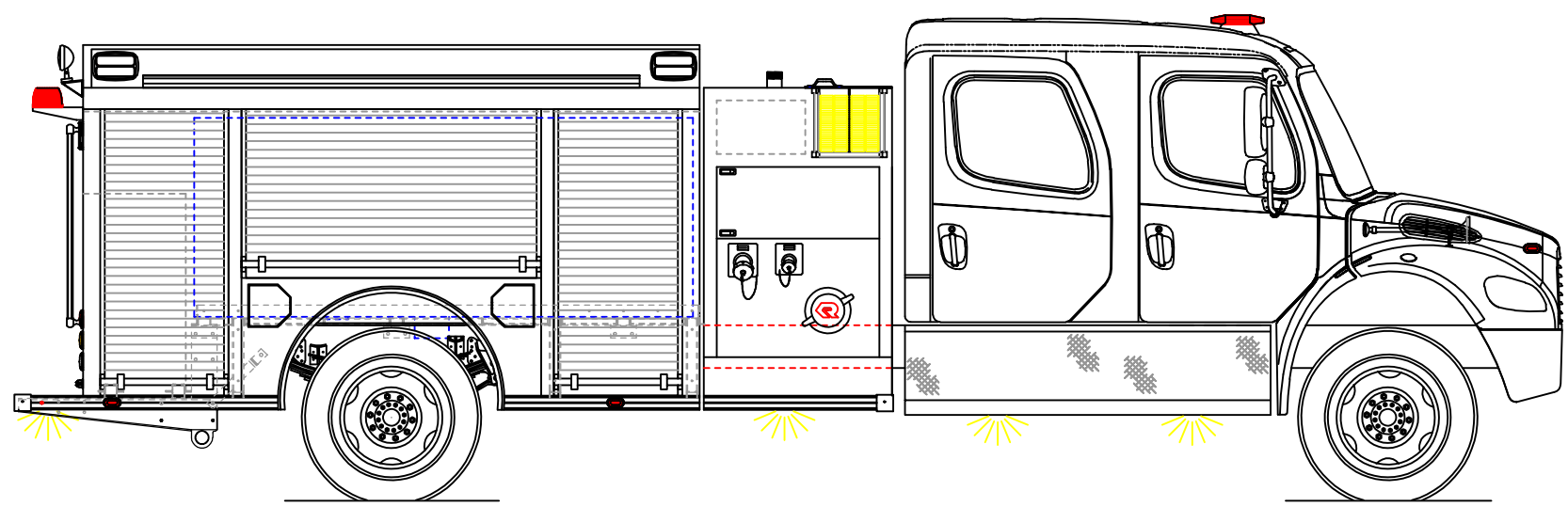

APPROVED BY:

CHASSIS:	FREIGHTLINER
PUMP:	DARLEY 1250 GPM
TANK:	POLY/1000
PANEL MATL:	LINE X

REVISED: -	DATE: -	COMP INTERIOR:	SPATTER FINISH
DRAWN: WLM	DATE: 05-29-18	MAXIMUM HEIGHT	NONE
PROPRIETARY AND CONFIDENTIAL THE INFORMATION CONTAINED IN THIS DRAWING IS THE SOLE PROPERTY OF ROSENBAUER. ANY REPRODUCTION IN PART OR AS A WHOLE WITHOUT THE WRITTEN PERMISSION OF ROSENBAUER IS PROHIBITED.		MAXIMUM LENGTH	NONE
		BODY WIDTH	98"

# STOCK COMMERCIAL 4DR RXT



ROSENBAUER RXT C/T

DRAWING NUMBER	REV
stock commercial 4dr rxt	-