

CHEVY SILVERADO 5500 2WD CHASSIS W/LIQUID SPRINGS SUSPENSION

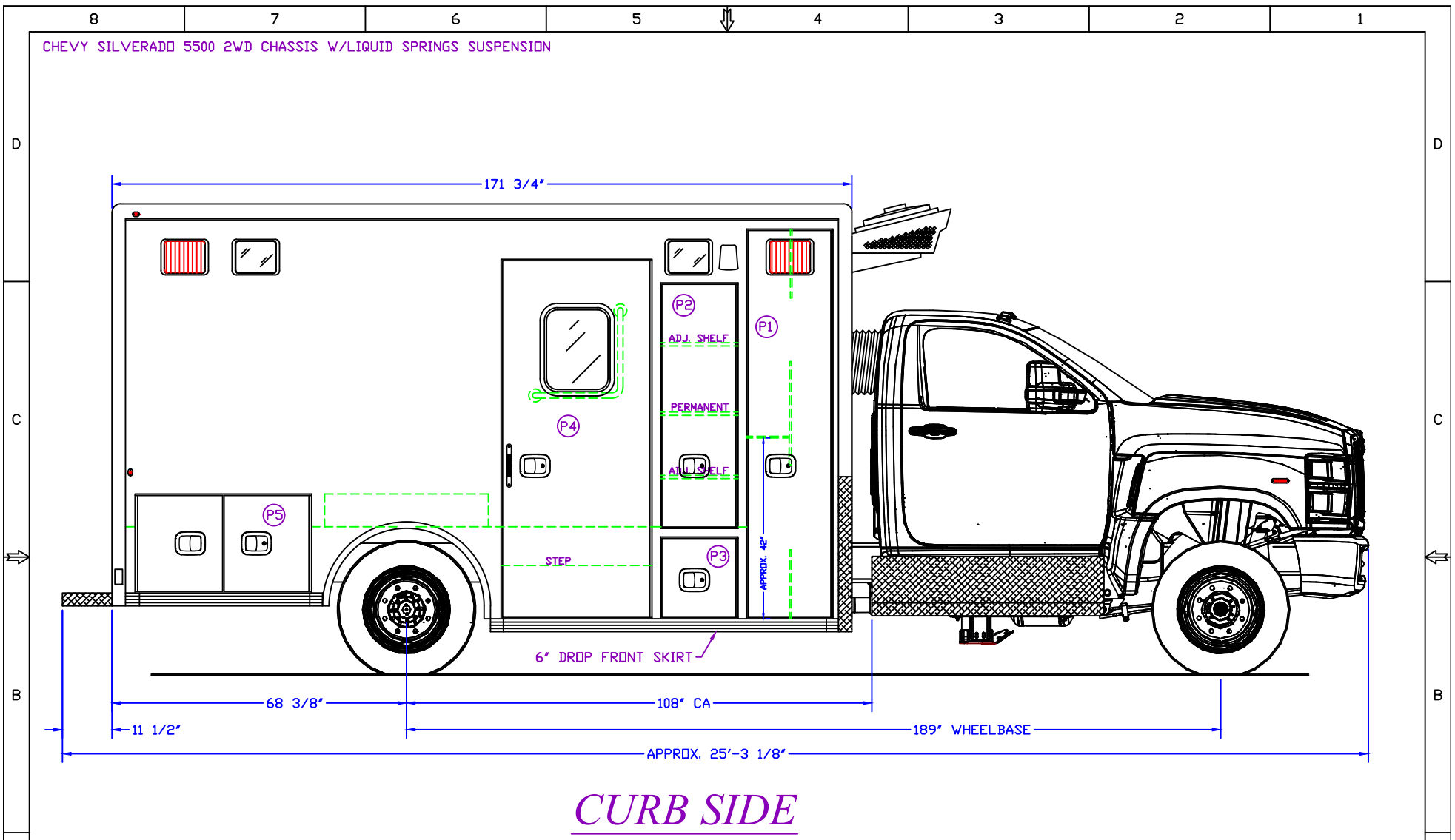

CURB SIDE

COMPT.	INTERIOR HEIGHT	PASS-THRU HEIGHT	INTERIOR WIDTH	PASS-THRU WIDTHS	DEPTH	DESCRIPTION	DRAWING NO: 4702-SMH1E
P1	89 1/2"	88 1/2"	19 1/2"	15"	20 7/8"	BACKBOARD/STAIR CHAIR	DRAWN BY: GM DATE: 9/19/19 SCALE: 1"=32" REVISION(S):
P2	56"	55"	20 1/2"	13"	26"	IS/OS STORAGE	
P3	18"	17"	17 1/2"	16"	19 1/4"	BATTERY STORAGE	
P4	72 1/4"	82 1/2"	34 1/2"	30"	---	SIDE ENTRANCE DOOR	
P5	22"	21"	40 1/2"	33"	19 1/4"	STORAGE	



LIFE LINE
EMERGENCY VEHICLES
1 Life Line Dr. P.O. Box 299
Sumner, IA 50674 Sumner, IA 50674

DIMENSIONS SHOWN ARE APPROXIMATE AND MAY CHANGE DURING THE CONSTRUCTION PROCESS. PRINTS ARE FOR GRAPHICAL REPRESENTATION ONLY AND NOT FOR DESIGN PURPOSES.

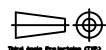
Tolerances:

 Ang. Tol: ±1°
 Dim. Tol: ±1"

THIS DRAWING IS THE PROPERTY OF LIFE LINE EMERGENCY VEHICLES, WHICH CLAIMS PROPRIETARY RIGHTS IN THE MATERIAL DISCLOSED. IT IS ISSUED IN CONFIDENCE FOR ENGINEERING INFORMATION ONLY AND MAY NOT BE COPIED OR USED FOR MANUFACTURING OF ANYTHING SHOWN WITHOUT SPECIFIC WRITTEN PERMISSION OF LIFE LINE EMERGENCY VEHICLES.

NOTES:
 FOR DRAWING APPROVAL
 APPROVED BY: _____
 TITLE: _____
 DATE: _____

171" TYPE I HIGHLINER ,72" HEADROOM
 FOR EAST COKE COUNTY AMBULANCE SERVICE - BRONTE, TX.

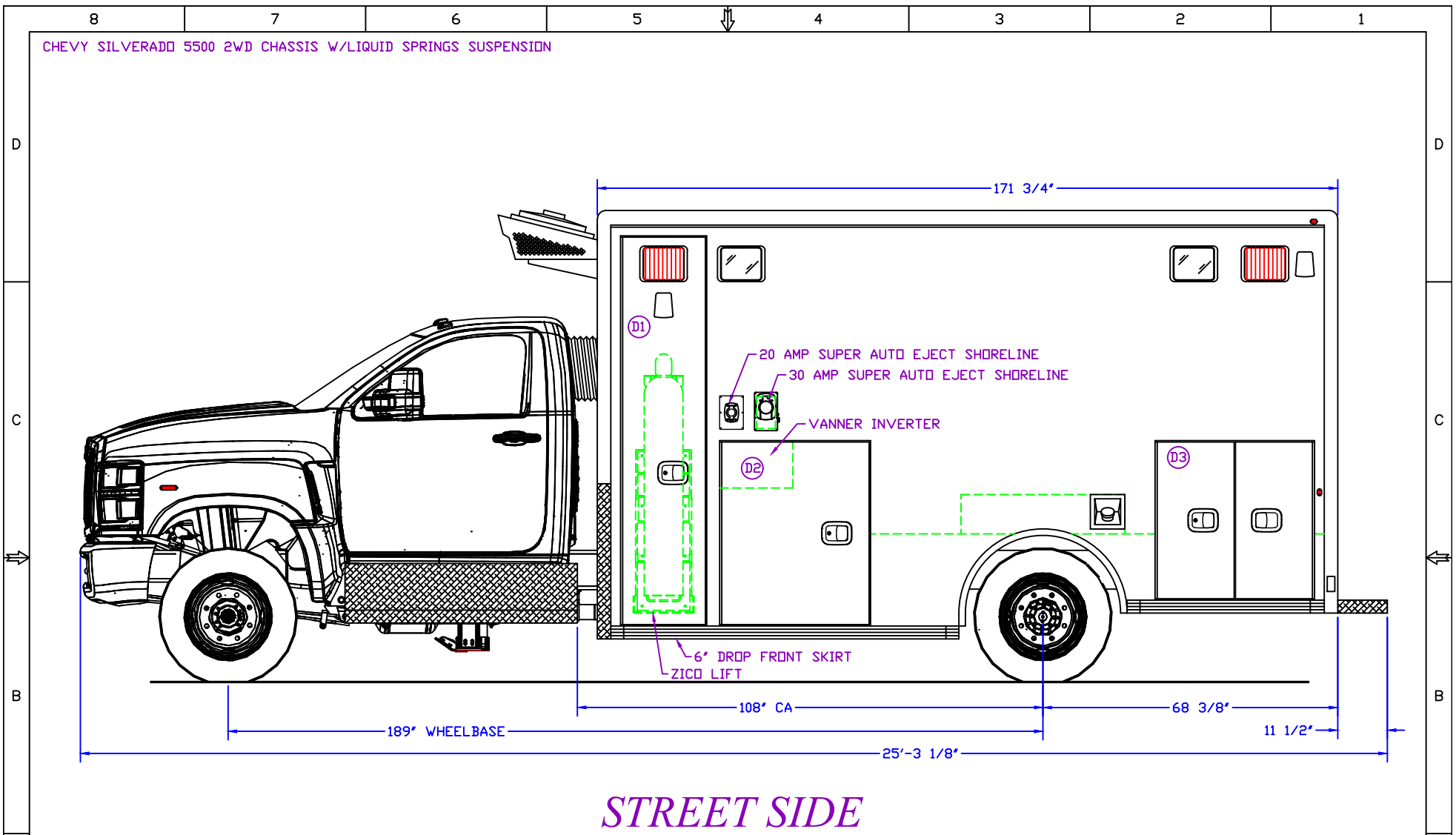
CHEVY SILVERADO 5500 2WD CHASSIS W/LIQUID SPRINGS SUSPENSION



STREET SIDE

COMPT.	INTERIOR HEIGHT	PASS-THRU HEIGHT	INTERIOR WIDTH	PASS-THRU WIDTHS	DEPTH	DESCRIPTION
D1	89 1/2"	88 1/2"	19 1/2"	15"	19 1/4"	O2 STORAGE
D2	42"	41"	34 1/2"	30"	19 1/4"	STORAGE
D3	36"	35"	36 1/2"	29"	19 1/4"	STORAGE

DRAWING NO:
4702-SMH1E

DRAWN BY: GM

DATE: 9/19/19

SCALE: 1"=32"

REVISION(S):



LIFE LINE
EMERGENCY VEHICLES

1 Life Line Dr. Sumner, IA 50674
P.O. Box 299 Sumner, IA 50674

DIMENSIONS SHOWN ARE APPROXIMATE AND MAY CHANGE DURING THE CONSTRUCTION PROCESS. PRINTS ARE FOR GRAPHICAL REPRESENTATION ONLY AND NOT FOR DESIGN PURPOSES.

Tolerances:
Third Angle Projection Only
Ang. Tol: ±1°
Dim. Tol: ±1"

THIS DRAWING IS THE PROPERTY OF LIFE LINE EMERGENCY VEHICLES, WHICH CLAIMS PROPRIETARY RIGHTS IN THE MATERIAL DISCLOSED. IT IS ISSUED IN CONFIDENCE FOR ENGINEERING INFORMATION ONLY AND MAY NOT BE COPIED OR USED FOR MANUFACTURING OF ANYTHING SHOWN WITHOUT SPECIFIC WRITTEN PERMISSION OF LIFE LINE EMERGENCY VEHICLES.

NOTE: SHIP SPARE TIRE LOOSE

FOR DRAWING APPROVAL

APPROVED BY: _____

TITLE: _____

DATE: _____

171" TYPE I HIGHLINER ,72" HEADROOM

FOR EAST COKE COUNTY AMBULANCE SERVICE - BRONTE, TX.

CHEVY SILVERADO 5500 2WD CHASSIS W/LIQUID SPRINGS SUSPENSION

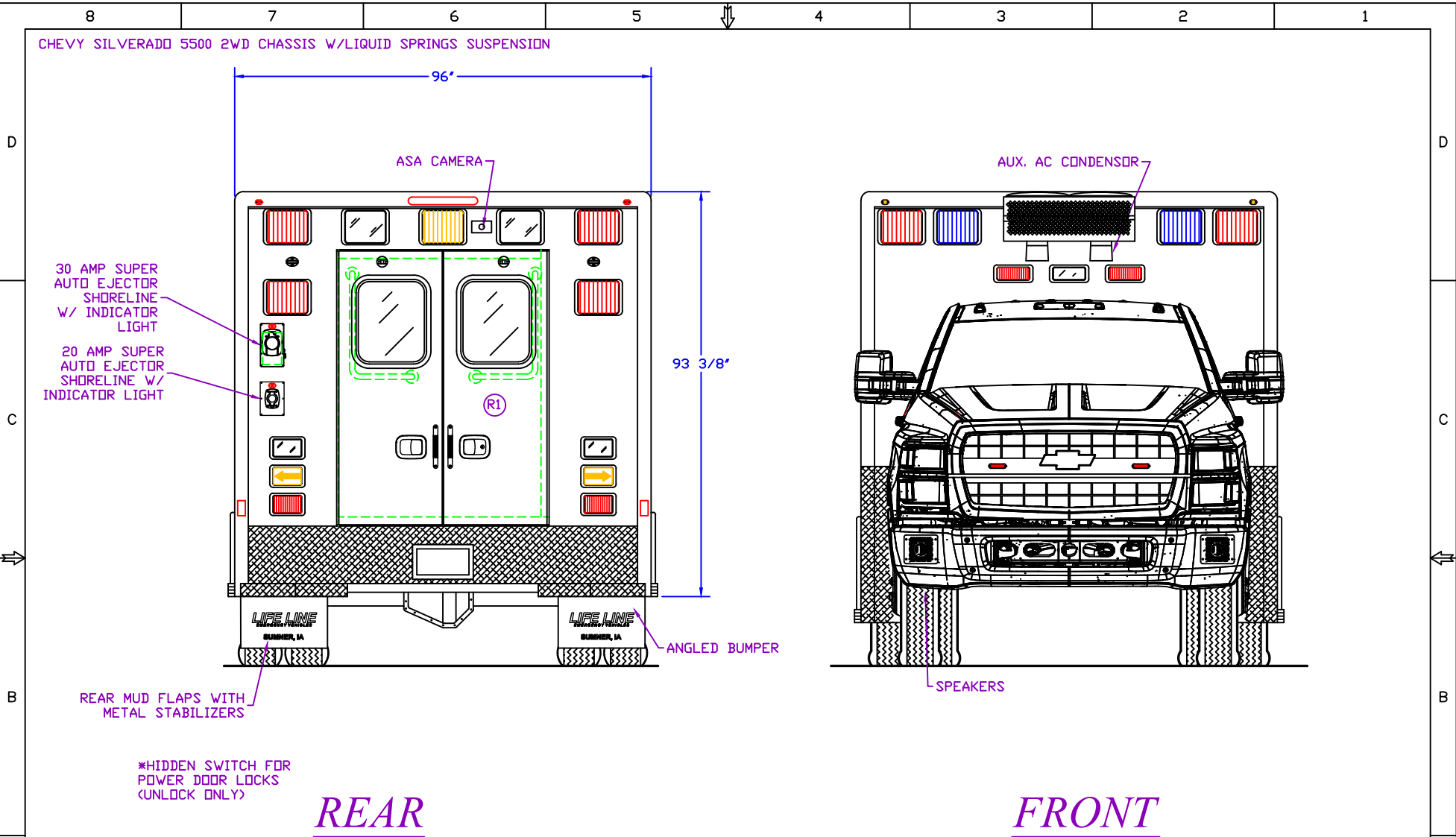

REAR

FRONT

COMPT.	INTERIOR HEIGHT	PASS-THRU HEIGHT	INTERIOR WIDTH	PASS-THRU WIDTHS	DEPTH	DESCRIPTION
R1	72 1/4"	60"	46 3/4"	46"	---	REAR ENTRANCE

DRAWING NO:
4702-SMH1E

DRAWN BY: GM
DATE: 9/19/19
SCALE: 1"=32"
REVISION(S):

LIFE LINE
EMERGENCY VEHICLES
1 Life Line Dr. P.O. Box 299
Sumner, IA 50674 Sumner, IA 50674

DIMENSIONS SHOWN ARE APPROXIMATE AND MAY CHANGE DURING THE CONSTRUCTION PROCESS. PRINTS ARE FOR GRAPHICAL REPRESENTATION ONLY AND NOT FOR DESIGN PURPOSES.

Tolerances:
3rd Angle Projection (ANSI)
Ang. Tol: ±1°
Dim. Tol: ±1"

THIS DRAWING IS THE PROPERTY OF LIFE LINE EMERGENCY VEHICLES, WHICH CLAIMS PROPRIETARY RIGHTS IN THE MATERIAL DISCLOSED. IT IS ISSUED IN CONFIDENCE FOR ENGINEERING INFORMATION ONLY AND MAY NOT BE COPIED OR USED FOR MANUFACTURING OF ANYTHING SHOWN WITHOUT SPECIFIC WRITTEN PERMISSION OF LIFE LINE EMERGENCY VEHICLES.

FOR DRAWING APPROVAL
APPROVED BY: _____
TITLE: _____
DATE: _____

**171" TYPE I HIGHLINER ,72" HEADROOM
FOR EAST COKE COUNTY AMBULANCE SERVICE - BRONTE, TX.**

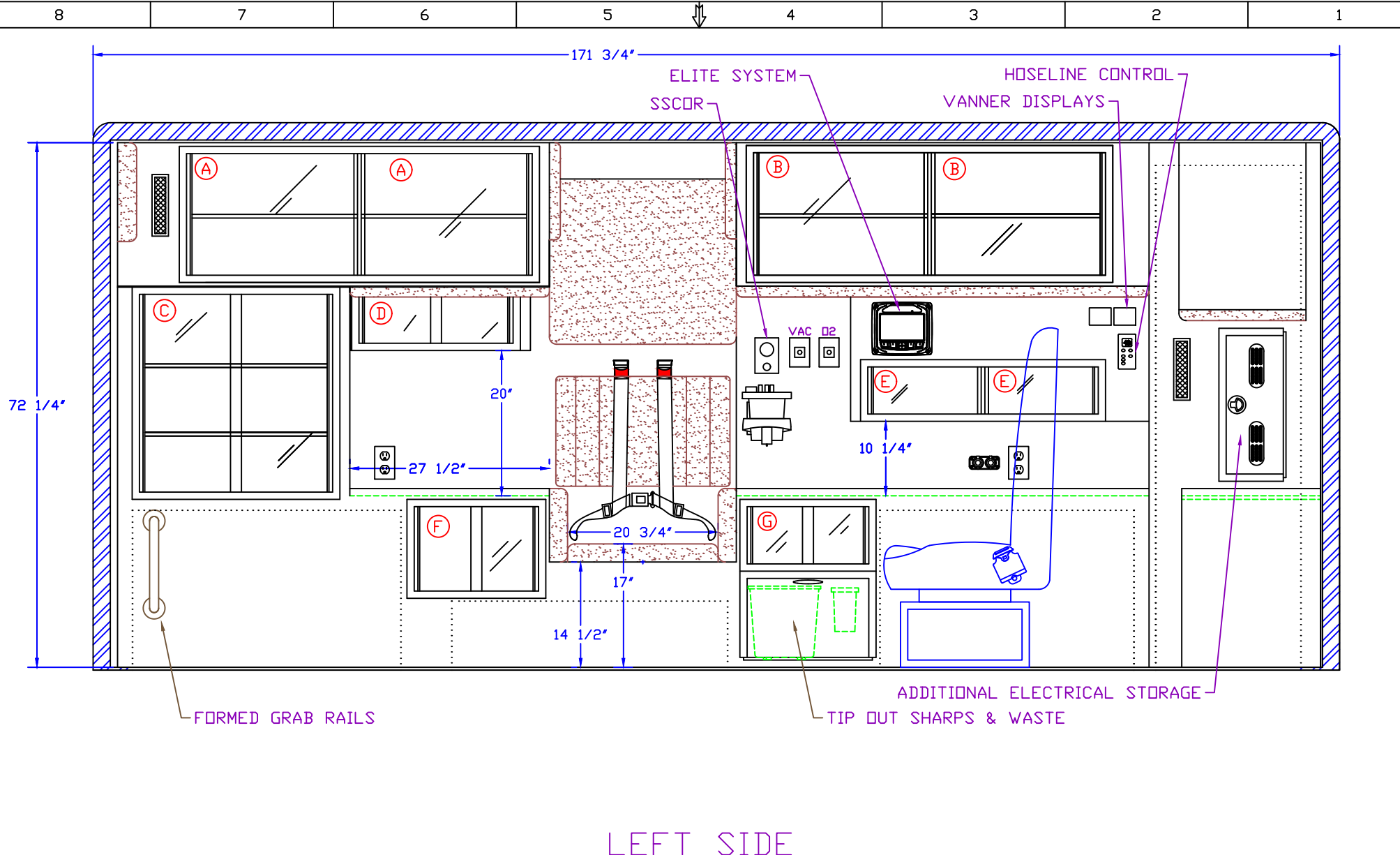

LEFT SIDE

CABINET	INTERIOR HEIGHT	INTERIOR WIDTH	INTERIOR DEPTH	DESCRIPTION	DOOR STYLE
A	18 3/4"	24"	18 1/4"	STORAGE	SLIDING POLYCARBONATE
B	18 3/4"	24 1/2"	18 1/4"	STORAGE	SLIDING POLYCARBONATE
C	28 1/4"	29"	19 3/4"	STORAGE	SLIDING POLYCARBONATE
D	7 3/4"	23 1/2"	8 1/2"	STORAGE	SLIDING POLYCARBONATE
E	7 1/2"	16"	4 1/2"	STORAGE	SLIDING POLYCARBONATE
F	12 1/2"	18"	19 3/4"	STORAGE	SLIDING POLYCARBONATE
G	8 1/4"	18 1/4"	19 1/4"	STORAGE	SLIDING POLYCARBONATE

DRAWING NO:
4702-SMH11

DRAWN BY: GM

DATE: 9/19/19

SCALE: 1"=19.5"

REVISION(S):

LIFE LINE

EMERGENCY VEHICLES

1 Life Line Dr. P.O. Box 299
Sumner, IA 50674 Sumner, IA 50674

DIMENSIONS SHOWN ARE APPROXIMATE AND MAY CHANGE DURING THE CONSTRUCTION PROCESS. PRINTS ARE FOR GRAPHICAL REPRESENTATION ONLY AND NOT FOR DESIGN PURPOSES.

Tolerances:
 Ang. Tol: ±1°
 Din. Tol: ±1"

THIS DRAWING IS THE PROPERTY OF LIFE LINE EMERGENCY VEHICLES, WHICH CLAIMS PROPRIETARY RIGHTS IN THE MATERIAL DISCLOSED. IT IS ISSUED IN CONFIDENCE FOR ENGINEERING INFORMATION ONLY AND MAY NOT BE COPIED OR USED FOR MANUFACTURING WITHOUT SPECIFIC WRITTEN PERMISSION OF LIFE LINE EMERGENCY VEHICLES.

FOR DRAWING APPROVAL

APPROVED BY: _____

TITLE: _____

DATE: _____

171" TYPE I HIGHLINER ,72" HEADROOM
FOR EAST COKE COUNTY AMBULANCE SERVICE - BRONTE, TX.

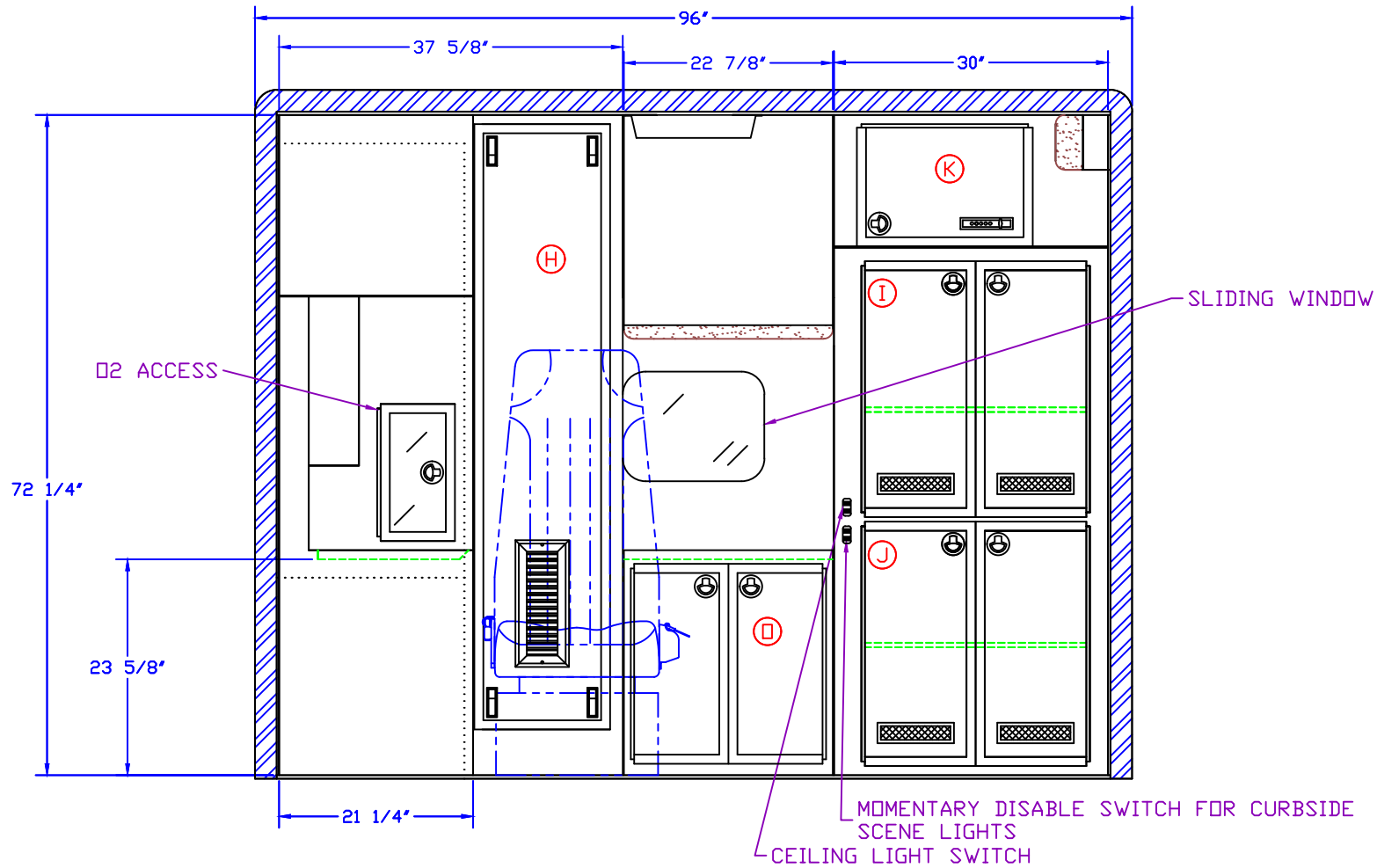

FRONT VIEW

CABINET	INTERIOR HEIGHT	INTERIOR WIDTH	INTERIOR DEPTH	DESCRIPTION	DOOR STYLE
H	71 1/4"	16"	9"	ELECTRICAL	REMOVABLE PANEL
I	28 1/2"	26"	20 1/2"	IS/OS STORAGE	SIDE HINGED DOUBLE SOLID DOORS
J	28"	26"	20 1/2"	IS/OS STORAGE	SIDE HINGED DOUBLE SOLID DOORS
K	13 3/8"	18 1/4"	20 1/2"	LOCKING STORAGE	TOP HINGED SOLID
O	21 3/4"	21 1/2"	17 1/2"	STORAGE	SIDE HINGED DOUBLE SOLID DOORS

DRAWING NO: **4702-SMH11**
 DRAWN BY: GM
 DATE: 9/19/19
 SCALE: 1"=19.5"
 REVISION(S): ---



LIFE LINE
EMERGENCY VEHICLES
 1 Life Line Dr. P.O. Box 299
 Sumner, IA 50674 Sumner, IA 50674

DIMENSIONS SHOWN ARE APPROXIMATE AND MAY CHANGE DURING THE CONSTRUCTION PROCESS. PRINTS ARE FOR GRAPHICAL REPRESENTATION ONLY AND NOT FOR DESIGN PURPOSES.



THIS DRAWING IS THE PROPERTY OF LIFE LINE EMERGENCY VEHICLES, WHICH CLAIMS PROPRIETARY RIGHTS IN THE MATERIAL DISCLOSED. IT IS ISSUED IN CONFIDENCE FOR ENGINEERING INFORMATION ONLY AND MAY NOT BE COPIED OR USED FOR MANUFACTURING OF ANYTHING SHOWN WITHOUT SPECIFIC WRITTEN PERMISSION OF LIFE LINE EMERGENCY VEHICLES.

FOR DRAWING APPROVAL
 APPROVED BY: _____
 TITLE: _____
 DATE: _____

171" TYPE I HIGHLINER ,72" HEADROOM
 FOR EAST COKE COUNTY AMBULANCE SERVICE - BRONTE, TX.

8 7 6 5 4 3 2 1

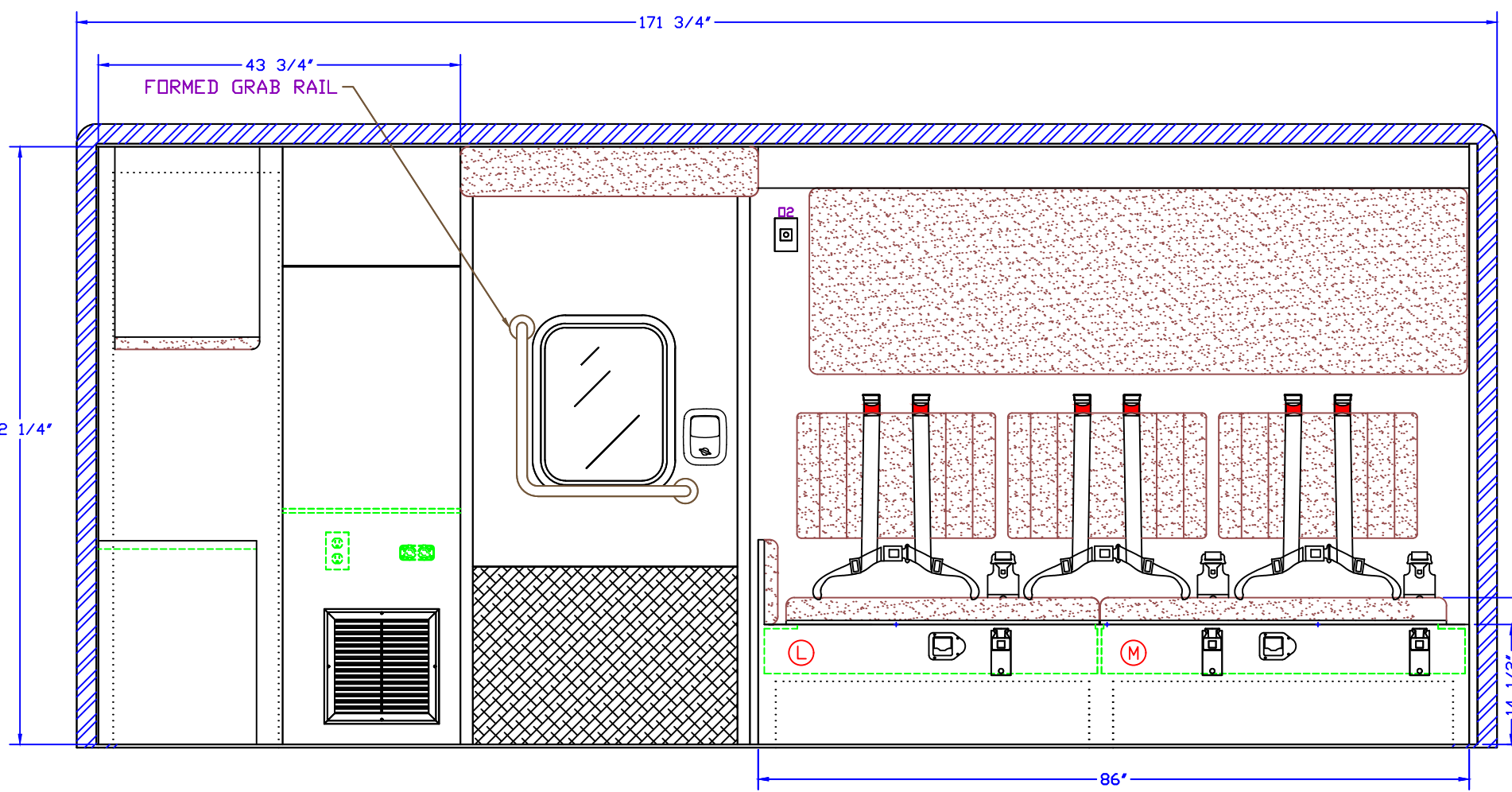

RIGHT SIDE

CABINET	INTERIOR HEIGHT	INTERIOR WIDTH	INTERIOR DEPTH	DESCRIPTION	DOOR STYLE
L	5 7/16"	40 1/4"	20 1/4"	STORAGE	TOP HINGED LID
M	5 7/16"	43 3/4"	20 1/4"	STORAGE	TOP HINGED LID

DRAWING NO: **4702-SMH11**
 DRAWN BY: GM
 DATE: 9/19/19
 SCALE: 1"=19.5"
 REVISION(S): ---

LIFE LINE
 EMERGENCY VEHICLES
 1 Life Line Dr. P.O. Box 299
 Sumner, IA 50674 Sumner, IA 50674

FOR DRAWING APPROVAL
 APPROVED BY: _____
 TITLE: _____
 DATE: _____

**171" TYPE I HIGHLINER ,72" HEADROOM
 FOR EAST COKE COUNTY AMBULANCE SERVICE - BRONTE, TX.**

DIMENSIONS SHOWN ARE APPROXIMATE AND MAY CHANGE DURING THE CONSTRUCTION PROCESS. PRINTS ARE FOR GRAPHICAL REPRESENTATION ONLY AND NOT FOR DESIGN PURPOSES.

Tolerances: Third angle projection (ANSI)
 Ang. Tol: ±1"
 Dim. Tol: ±1"

THIS DRAWING IS THE PROPERTY OF LIFE LINE EMERGENCY VEHICLES, WHICH CLAIMS PROPRIETARY RIGHTS IN THE MATERIAL DISCLOSED. IT IS ISSUED IN CONFIDENCE FOR ENGINEERING INFORMATION ONLY AND MAY NOT BE COPIED OR USED FOR MANUFACTURING WITHOUT WRITTEN PERMISSION OF LIFE LINE EMERGENCY VEHICLES.

8 7 6 5 4 3 2 1

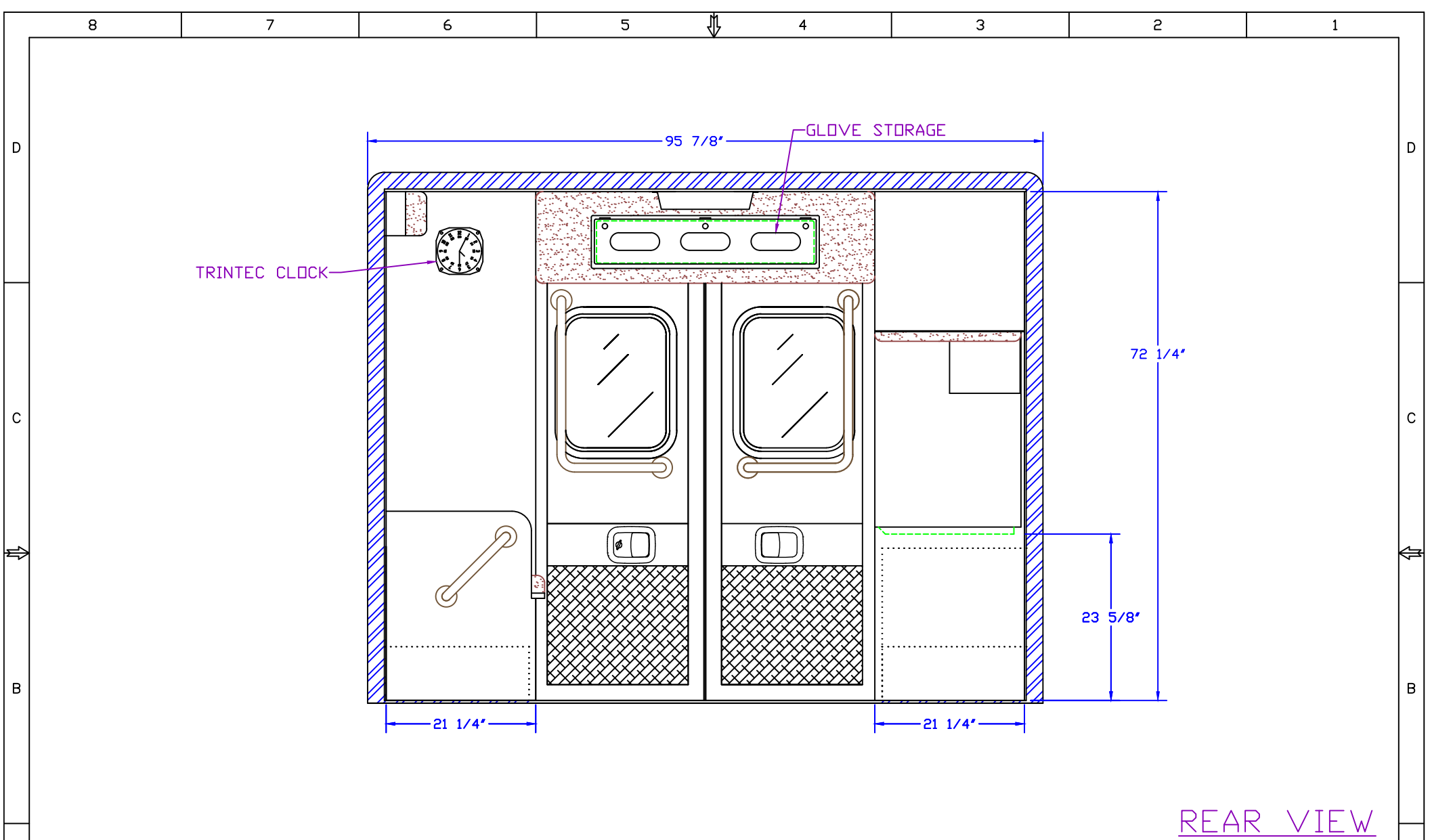

CABINET	INTERIOR HEIGHT	INTERIOR WIDTH	INTERIOR DEPTH	DESCRIPTION	DOOR STYLE

DRAWING NO: **4702-SMH11**

DRAWN BY: GM

DATE: 9/19/19

SCALE: 1"=19.5"

REVISION(S):

LIFE LINE
EMERGENCY VEHICLES

1 Life Line Dr. P.O. Box 299
Sumner, IA 50674 Sumner, IA 50674

DIMENSIONS SHOWN ARE APPROXIMATE AND MAY CHANGE DURING THE CONSTRUCTION PROCESS. PRINTS ARE FOR GRAPHICAL REPRESENTATION ONLY AND NOT FOR DESIGN PURPOSES.

Tolerances:

3rd Angle Projection (ANSI)

Ang. Tol: ±1'
Dim. Tol: ±1'

THIS DRAWING IS THE PROPERTY OF LIFE LINE EMERGENCY VEHICLES, WHICH CLAIMS PROPRIETARY RIGHTS IN THE MATERIAL DISCLOSED. IT IS ISSUED IN CONFIDENCE FOR ENGINEERING INFORMATION ONLY AND MAY NOT BE COPIED OR USED FOR MANUFACTURING OF ANYTHING SHOWN WITHOUT SPECIFIC WRITTEN PERMISSION OF LIFE LINE EMERGENCY VEHICLES.

FOR DRAWING APPROVAL

APPROVED BY: _____

TITLE: _____

DATE: _____

**171" TYPE I HIGHLINER ,72" HEADROOM
FOR EAST COKE COUNTY AMBULANCE SERVICE - BRONTE, TX.**

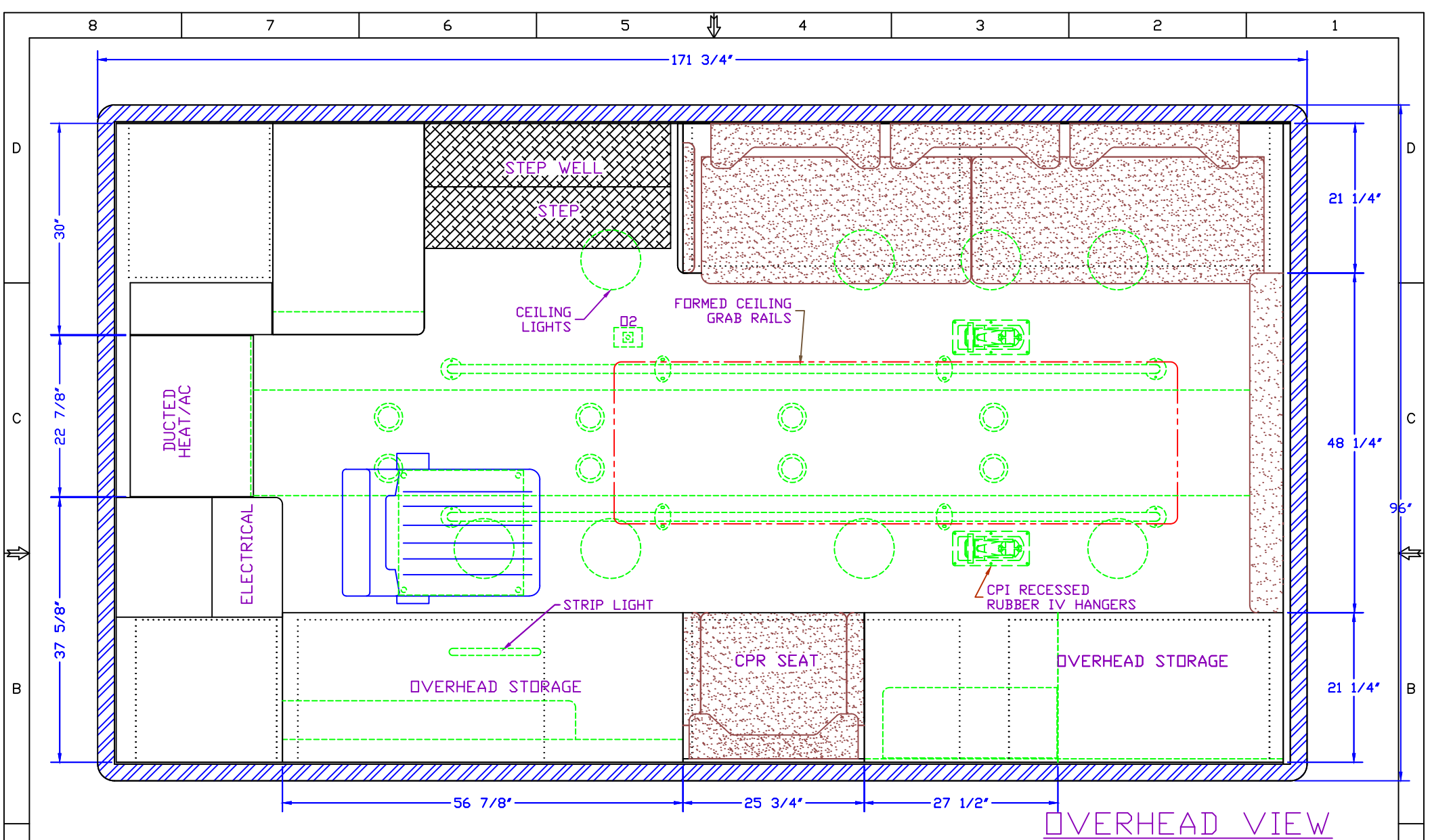

OVERHEAD VIEW

CABINET	INTERIOR HEIGHT	INTERIOR WIDTH	INTERIOR DEPTH	DESCRIPTION	DOOR STYLE

DRAWING NO: **4702-SMH11**
 DRAWN BY: GM
 DATE: 9/19/19
 SCALE: 1"=19.5"
 REVISION(S): ---



LIFE LINE
EMERGENCY VEHICLES
 1 Life Line Dr. P.O. Box 299
 Sumner, IA 50674 Sumner, IA 50674

DIMENSIONS SHOWN ARE APPROXIMATE AND MAY CHANGE DURING THE CONSTRUCTION PROCESS. PRINTS ARE FOR GRAPHICAL REPRESENTATION ONLY AND NOT FOR DESIGN PURPOSES.

Tolerances:

 Ang. Tol: ±1'
 Dim. Tol: ±1'

THIS DRAWING IS THE PROPERTY OF LIFE LINE EMERGENCY VEHICLES, WHICH CLAIMS PROPRIETARY RIGHTS IN THE MATERIAL DISCLOSED. IT IS ISSUED IN CONFIDENCE FOR ENGINEERING INFORMATION ONLY AND MAY NOT BE COPIED OR USED FOR MANUFACTURING OF ANYTHING SHOWN WITHOUT SPECIFIC WRITTEN PERMISSION OF LIFE LINE EMERGENCY VEHICLES.

FOR DRAWING APPROVAL
 APPROVED BY: _____
 TITLE: _____
 DATE: _____

171" TYPE I HIGHLINER ,72" HEADROOM
 FOR EAST COKE COUNTY AMBULANCE SERVICE - BRONTE, TX.

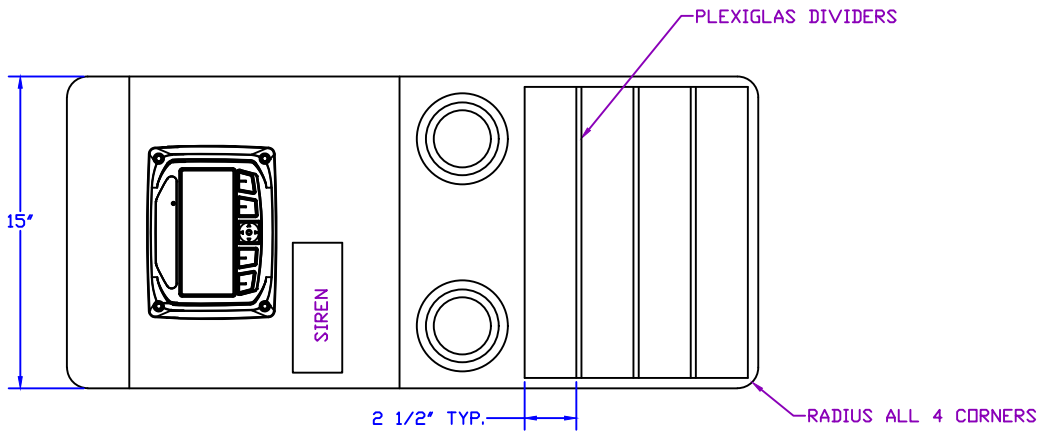
8 7 6 5 4 3 2 1



TOP VIEW

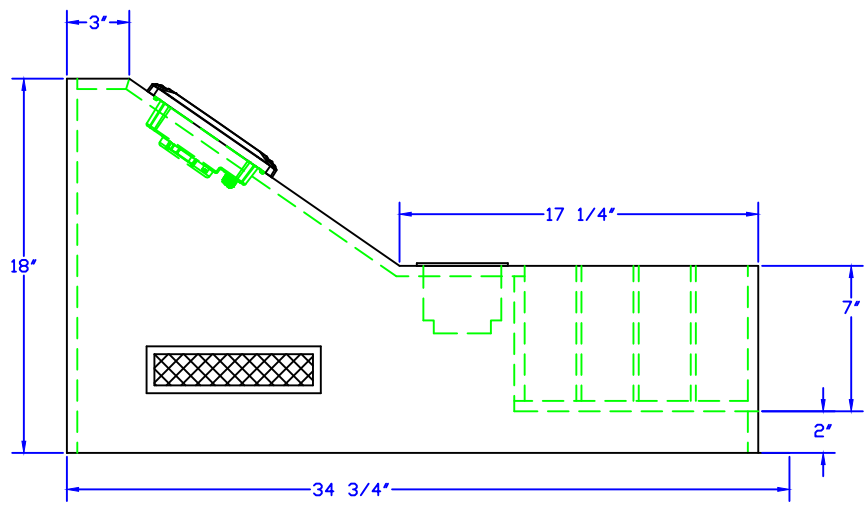

SIDE VIEW

*FINAL DESIGN TBD

DRAWING NO:	4702-CON
DRAWN BY:	GM
DATE:	9/19/19
SCALE:	NTS
REVISION(S):	---

LIFE LINE
EMERGENCY VEHICLES
1 Life Line Dr. P.O. Box 299
Sumner, IA 50674 Sumner, IA 50674

DIMENSIONS SHOWN ARE APPROXIMATE AND MAY CHANGE DURING THE CONSTRUCTION PROCESS. PRINTS ARE FOR GRAPHICAL REPRESENTATION ONLY AND NOT FOR DESIGN PURPOSES.

Tolerances:

 Ang. Tol: ±1°
 Dim. Tol: ±1'

THIS DRAWING IS THE PROPERTY OF LIFE LINE EMERGENCY VEHICLES, WHICH CLAIMS PROPRIETARY RIGHTS IN THE MATERIAL DISCLOSED. IT IS ISSUED IN CONFIDENCE FOR ENGINEERING INFORMATION ONLY AND MAY NOT BE COPIED OR USED FOR MANUFACTURING OF ANYTHING SHOWN WITHOUT SPECIFIC WRITTEN PERMISSION OF LIFE LINE EMERGENCY VEHICLES.

FOR DRAWING APPROVAL
 APPROVED BY: _____
 TITLE: _____
 DATE: _____

**171" TYPE I HIGHLINER ,72" HEADROOM
 FOR EAST COKE COUNTY AMBULANCE SERVICE - BRONTE, TX.**

8 7 6 5 4 3 2 1